

INSTALLATION & USER INSTRUCTIONS

Thank you for purchasing this Whale® product.

For over 60 years Whale® has led the way in the design and manufacturer of freshwater and waste systems including:- plumbing, faucets, showers and pumps for mobile applications. Today's range features space and water heaters for caravans and motorhomes. The company and its products have built a reputation for quality, reliability and innovation backed up by excellent customer service.

For information on our full product range visit: www.whalepumps.com

CONTENTS

1.	Principles of Operation
2.	Specification
3.	Application
4.	Warnings
5.	Parts List
6.	Instructions for Installation
7.	Instructions for Use
8.	Maintenance
9.	Trouble Shooting
10.	Winterising
11.	Service Support Details
12.	EU Declaration of Conformity
13.	Patents and Trademarks
14.	Warranty

LIST OF IMAGES

Fig. 1	Components drawing
Fig. 2	Installation
Fig. 3	Dimensions – Plan View
Fig. 4	Dimensions – Side View
Fig. 5	Dimensions – Front View
Fig. 6	Flue Locating Diagram
Fig. 7	Floor Construction and Cut Out
Fig. 8	Positioning the Space Heater
Fig. 9	Securing the Space Heater (Plan View)
Fig. 10	Attaching Flues
Fig. 11	Secure Flue Brackets
Fig. 12	Connect to Gas Supply
Fig. 13	Fitting Hot Air Ducts
Fig. 14	Tee Fitting Orientation
Fig. 15	Fitting Cold Air Ducts
Fig. 16	Insert Control Panel
Fig. 17	Secure Control Panel
Fig. 18	Installed Control Panel
Fig. 19	Connect 12V to Interface Plate
Fig. 20	Mains Electrical Connection
Fig. 21	Completed Installation
Fig. 22	Whale Space Heater Control Panel
Fig. 23	Whale Duo Control Panel
Fig. 24	Whale iVan Control Panel
Fig. 25	Reset Button Location
Fig. 26	Flue Type - For Standard Installation C ₅₃
Fig. 27	Flue Type - For Vehicle In Motion C ₁₃

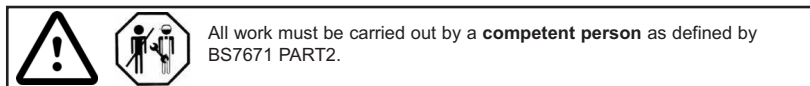
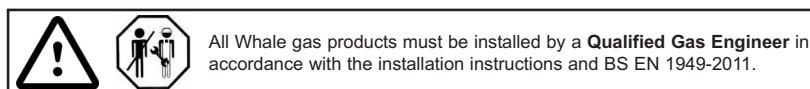

Please note if incorrectly installed a risk of electrocution exists.

1. PRINCIPLES OF OPERATION

The Whale® 4kW Space Heater is an underfloor gas and electric blown air Space Heater. Nominal heat input is 2.9kW on gas and 2kW on mains electric. The 4kW Space Heater features a boost setting which varies the heat output depending on the temperature of the vehicle. It continually checks the temperature to establish the best settings to use, and is capable of using 2.9kW gas and up to 1kW electric simultaneously to provide the best available output. The underfloor design provides versatility in installation locations and it needs only minimal maintenance.

Read the following carefully before installation.

2. SPECIFICATION

Model SH4312B or SI4312B or SC4312B

Maximum dimensions: Height: 185mm, Width: 306mm, Length: 817mm

Countries of Destination: AT, BE, BG, CY, CZ, DE, DK, EE, FI, FR, GB, GR, HU, HR, IS, IT, LT, LU, LV, MT, NL, NO, PL, PT, RO, SE, SI, SK, TR

Weight: 10.9kg

Gas: Butane/Propane 30mbar - CAT I_{3B/P} (30)

Note: For use in road vehicles (caravans and motorhomes) only

Gas Consumption (M) 220g/hr

Classification of Heater: Type: C₅₃ (Fanned) Normal Installation
C₁₃ Vehicle In Motion Installation

Nominal Heat Input on Gas: 2.9Kw

Nominal Heat Input on Electric: 2.0kW

Max Heat Input on Dual/ Boost: 3.9kW

Mains Electric:

Nominal voltage: 230V a.c. 50Hz

Power options: 500W / 1000W / 2000W

Maximum current a.c.: 9 Amps

Battery Supply

Nominal voltage: 12V d.c.

Operating range: 11.5V d.c. min. to 15V d.c. max. when using electric high

Maximum current d.c. gas operation: 2.8 Amps (0.01 Amps on standby)

Maximum current d.c. electric operation: 2.2 Amps (0.01 Amps on standby)

Maximum current d.c. dual operation: 3.6 Amps

Dry Storage Temperature: -20°C to 70°C

Hot Air Duct Diameter: 60mm ID

Flue Diameter: 22mm ID

Maximum Exhaust Flue Length: 2 metres

Minimum Exhaust Flue Length: 0.75 metres

Maximum Combustion Air Flue Length: 2 metres

Minimum Combustion Air Flue Length: 0.75 metres

The Space Heater position **must allow** access for servicing the Space Heater.

For use in road vehicles only, i.e. caravans and motorhomes. Not suitable for caravan holiday homes i.e. mobile homes or static caravans.

Whale's policy is one of continuous improvement and we reserve the right to change specifications without prior notice.

3. APPLICATION

The Whale 4kW Space Heater has been designed for caravan and motorhome applications for typical recreational use. It is only suitable for use in road vehicles, i.e. caravans and motorhomes, but is not suitable for caravan holiday homes, i.e. mobile homes or static caravans. The Space Heater is designed to be installed with a ducted hot air system and **must not** be used in conjunction with any other system.



Do not operate the appliance while the vehicle is in motion, unless fitted with a vehicle in motion kit.



This symbol indicates that this appliance is suitable for use in Leisure Accommodation Vehicles.



This symbol indicates that this appliance is **not** suitable for use in boats.

4. WARNINGS



Observe all warnings.

In the unlikely event of leaks in the gas system, or if there is a smell of gas:

- Extinguish all naked flames
- Switch off all appliances and do not operate any electrical switches
- Turn off all gas appliances
- Open windows and doors for ventilation
- Do not smoke
- Shut off gas connection

Ensure that the system is immediately thoroughly checked by a registered gas engineer at a Whale® Approved Service Centre or by a member of the Whale Service Engineer Network.

The Space Heater **must not** be operated in the following situations:

- When refuelling the vehicle or refuelling the vehicle towing the caravan or refuelling any other appliance.
- When the vehicle in which the Space Heater is installed is in motion, unless a vehicle in motion kit is installed. Please see Appendix for information on identifying flue type.
- When the vehicle in which the Space Heater is installed is in a confined space (such as a garage).

This appliance is **not** intended for use by persons (including children) with reduced physical, sensory or mental capabilities, or lack of experience and knowledge, unless they have been given supervision or instruction concerning use of the appliance by a person responsible for their safety. Children **must be** supervised to ensure that they do not play with the appliance.

A minimum of one of the hot air outlet vents **must be** permanently open on each duct branch. This hot air vent **must be** the furthest from the Space Heater.

Any alteration to the appliance, including flue components, use of non-Whale® spare parts/accessories and non-observation of the installation and operation instructions shall lead to cancellation of the warranty and exclusion of liability claims and results in it becoming illegal to use the appliance.

Please note: Incorrect installation, misuse or use of non-original Whale® parts may invalidate the warranty. It also becomes illegal to use the appliance if incorrectly installed, and in some countries this even makes it illegal to use the vehicle.

When operating the Space Heater using gas, the combustion air inlet flue and outlet flue for the products of combustion (exhaust flue) **must never** be obstructed. They **must be** checked regularly, and if necessary cleaned by

the user (e.g. in winter, snow **must be** removed from the combustion outlet and air intake).

Where the open end of the exhaust flue terminates, three sides of the underfloor space **must be** kept open and not obstructed, and **must not** contain through floor ventilation openings.

The Space Heater, its gas supply and flues for the products of combustion **must be** inspected in accordance with national regulations or if these do not exist, the manufacturer's recommendations. Whale advises that this **must be** carried out at least annually.



Please note: The Space Heater and ducts will become hot. Avoid anything directly touching the Space Heater or ducts.



Please note: The Space Heater must not be used whilst the vehicle is in motion, permanent labels must be attached on the LPG cylinder compartment and in close proximity to the Control Panel, giving instructions that the Space Heater must not be used and the LPG cylinder valve must be closed when the vehicle is in motion.

5. PARTS LIST

The Whale® Space Heater kit contains:

	SH4312B or SI4312B or SC4312B
Space Heater	1
Warranty registration card	1
Instruction manual including installation templates	1

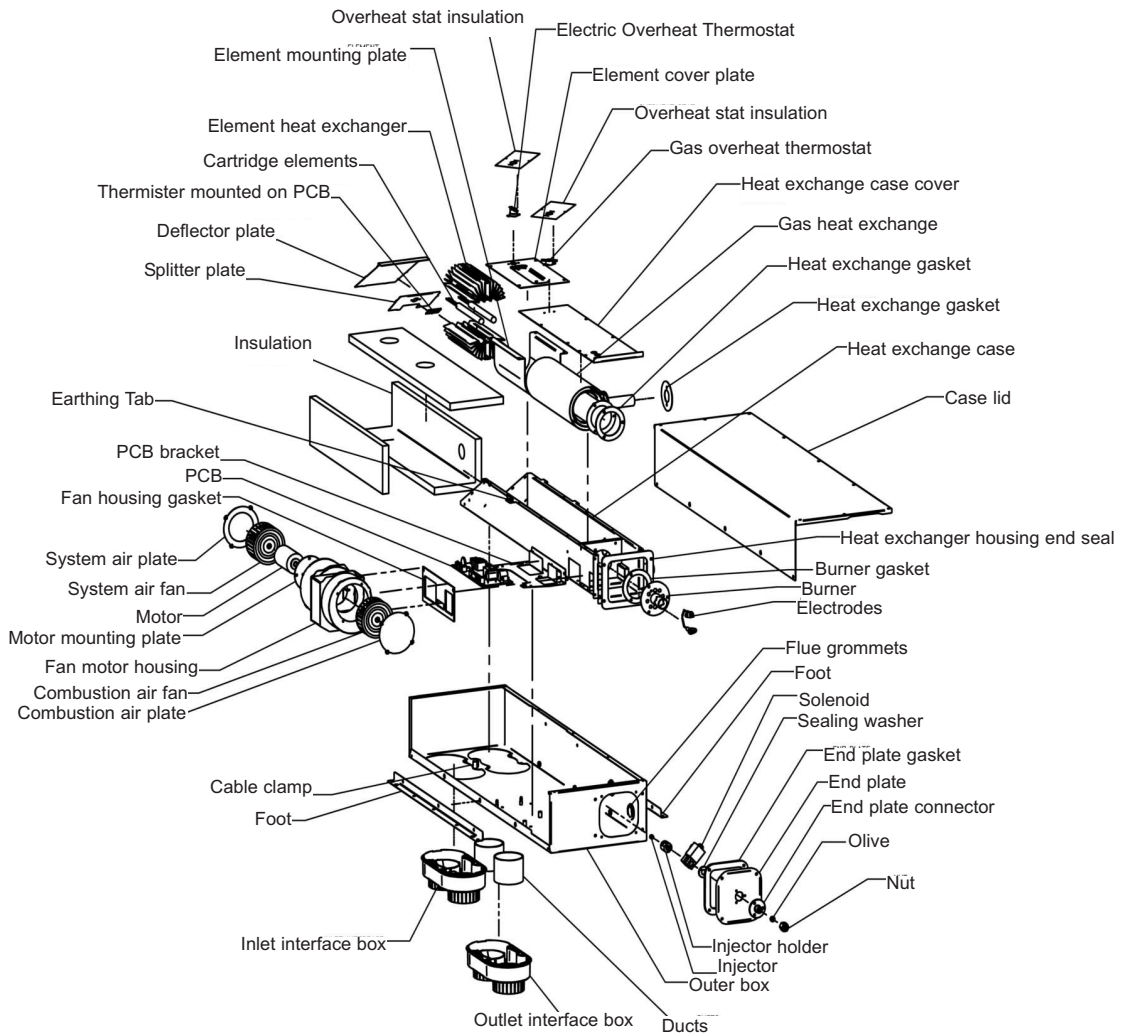

Fig. 1 - Components Drawing

Please note: The Whale® Space Heater requires a separate flue kit for installation. Exhaust flues are available in lengths of 0.75 metres, 1.25 metres and 2 metres. Combustion air inlet flues are available in lengths of 0.75 metres, 1.25 metres and 2 metres.

6. INSTRUCTIONS FOR INSTALLATION

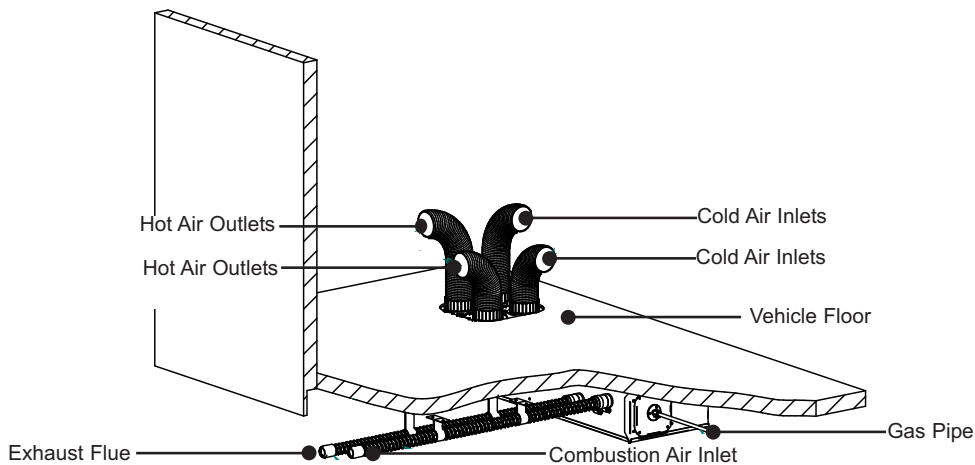

Fig. 2 - Installation

The Whale® 4kW Space Heater (Part Number SH4312B or SI4312B or SC4312B) is installed under the floor of the caravan as shown in Fig. 2.

To the fitter:

Installation and servicing of this appliance **must only** be carried out by competent persons registered with the Gas Safe Register (GB) or the relevant national organisation, in accordance with the relevant regulatory and safety requirements.

Before installation, you **must** ensure that the appliance has been supplied in good condition and if damaged **do not** install.

A competent person **must** install the appliance in accordance with the appliance installation instructions. This appliance is for use with LPG (see appliance data plate) and mains electricity (230V a.c.). Check that the product is suitable for the intended application. In particular, the installer **must check** the compatibility of the data plate information with the LPG supply requirements of the vehicle. Follow these installation instructions and ensure that all relevant personnel read the points listed below. Ensure that these operating instructions are passed on to the end user.

Please note: The appliance **must only** be installed in accordance with any relevant regulations in the country where the appliance is installed. For this appliance in Europe the standard is BS EN 1949:2011 "Specification for the Installation of LPG Systems for Habitation Purposes in Leisure Accommodation Vehicles and in Other Road Vehicles".

Ventilation **must** comply with relevant national and/or local requirements.

Please note: The Space Heater **must not** be used whilst the vehicle is in motion, permanent labels **must** be attached on the LPG cylinder compartment and in close proximity to the control panel, giving instructions that the Space Heater **must not** be used and the LPG cylinder valve **must be** closed when the vehicle is in motion.

DIMENSIONS

Underfloor Installation

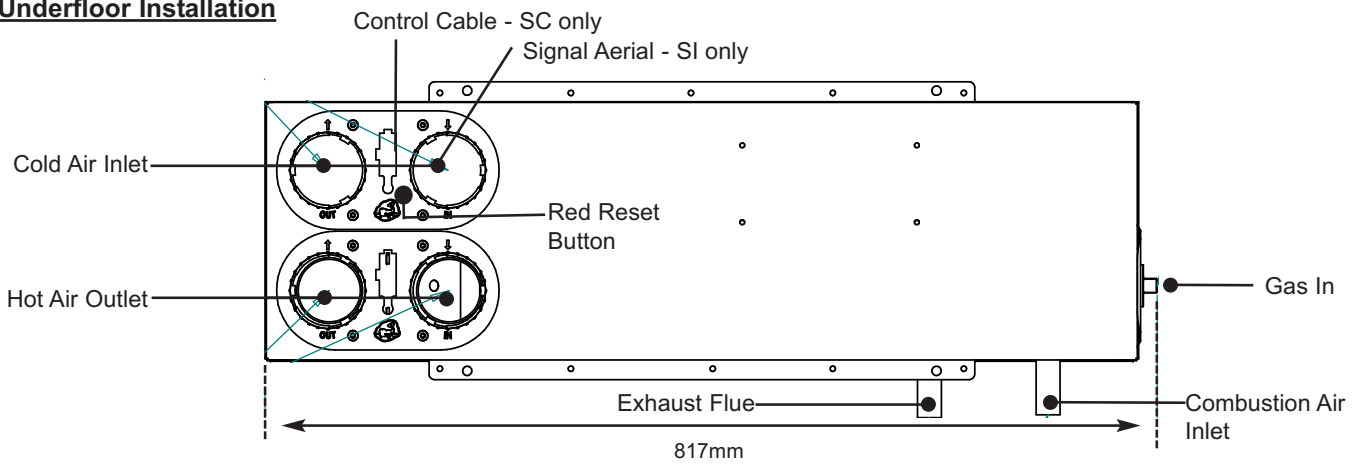

Fig. 3 - Dimensions Plan View

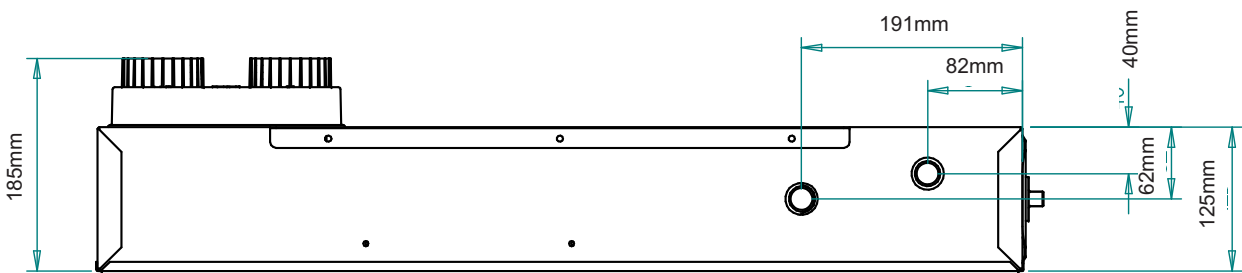

Fig. 4 - Dimensions - Side View

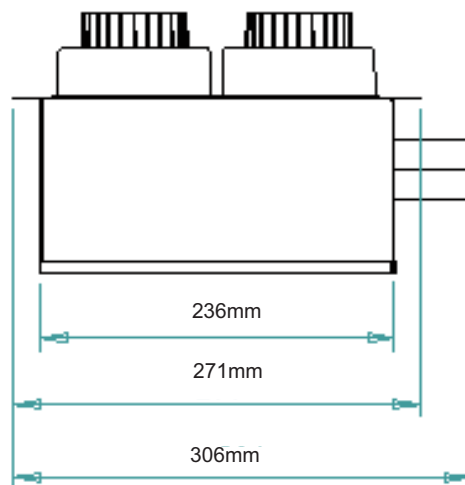

Fig. 5 - Dimensions Front View

Step 1: Find Suitable Location for Space Heater Installation

Consider the following points:

- i. For weight distribution in caravans, it is best to position the Space Heater as near to the axle as possible. You **must** avoid (where possible) locating at the very rear and preferably avoid the very front.
- ii. The Space Heater **must be** positioned within the chassis members and close to the axle to help protect the appliance.
- iii. Please note: The Space Heater, ducts and flues will become hot. Avoid anything directly touching these.
- iv. Ensure the position allows access for servicing the Space Heater and that there is a minimum of 25mm distance around the Space Heater to adjacent walls.
- v. The hot air outlet of the Space Heater **must be** fitted to the hot air ducting system. The Space Heater **must be** positioned to minimise the amount of ducting required and sharp bends in the ducting **must be** avoided.
- vi. In selecting the position of the Space Heater, ensure that the exhaust flue and combustion air inlet flues can be installed avoiding all chassis members and gas pipes etc. that are located underneath the floor.
- vii. The open end of the exhaust flue **must not** be fitted at the side of the caravan / motorhome where an awning may be fitted. You **must install** the Space Heater on the opposite side of the caravan / motorhome to avoid routing the exhaust flue to the far side of the caravan / motorhome.
- viii. Only Whale® supplied flue components are permitted to be used. The open end of either flue **must not** be positioned within 500mm of a refuelling point or fuel tank breather outlet or any ventilator from the fuel system(s). The exhaust flue **must not be** fitted within 300mm of a ventilator for the living space or an opening part of a window. The open end of the exhaust flue **must be** positioned at least 500mm from the open end of the combustion air flue and **must be** pointing in the same direction. The exhaust flue **must be** positioned at the side or end of the caravan / motorhome. The exhaust flue **must only be** positioned vertically below an opening part of a window if the appliance is fitted with an automatic shut-off device, to prevent operation when the window is open.

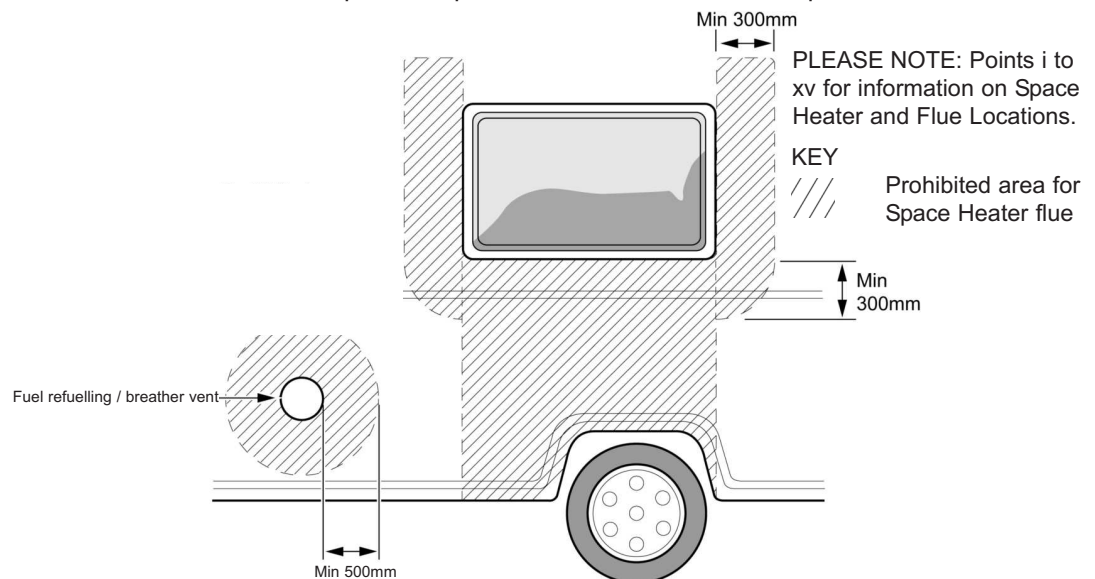

Fig. 6 - Flue Locating Diagram

- ix. The combustion air inlet flue can be terminated underneath the vehicle. The open end of the flue **must be** at least 500mm away from the open end of the exhaust flue, and pointing in the same direction. Take care to ensure that both flues have a slight downward slope from as close to the Space Heater as possible to prevent any possibility of water traps. Ensure that neither the exhaust nor the combustion air inlet flues are terminated in an under-floor box section.
- x. The minimum length of the exhaust flue is 0.75 metres, and maximum length 2 metres. The minimum length of the combustion air inlet flue inlet must be 0.75 metres, and maximum length 2 metres.
- xi. When operating the Space Heater using gas, the combustion air inlet flue and outlet openings for the products of combustion (exhaust flue) **must not** be obstructed. They **must be** checked regularly, and if necessary cleaned by the user (e.g. in winter, snow **must be** removed from the exhaust flue and combustion air inlet flue).

- xii. Where the open end of the exhaust flue terminates, three sides of the underfloor space **must be** kept open and not obstructed, and **must not** contain through-floor ventilation openings.
- xiii. The Space Heater, its gas supply, ducting and flues **must be** inspected in accordance with national regulations or if these do not exist, the manufacturer's recommendations, however, Whale advises that this must be done at least annually.
- xiv. The Space Heater **must not** be used when the vehicle is in motion.
- xv. The user must have access to the reset button.

Step 2: Space Heater Location

For installation, the floor of the vehicle **must be** manufactured as per Fig. 7. Wooden batons **must be** incorporated in the floor's construction to secure the screws into. Screws may also be used for additional support, but the Space Heater must be secured using 4 through-floor bolts for securing the Space Heater.

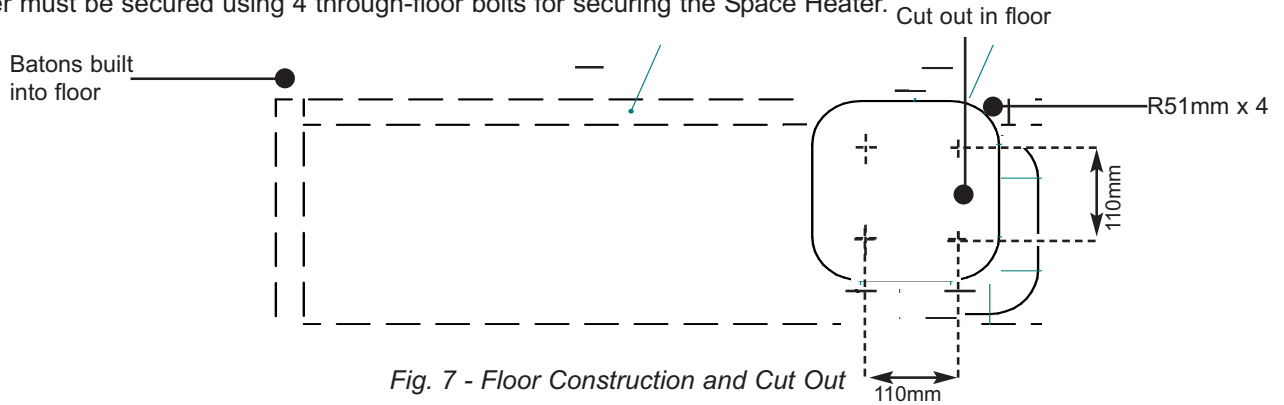

Fig. 7 - Floor Construction and Cut Out

Locate the Space Heater in the correct position so that the brackets are aligned with the batons and attach with 4 x M8 bolts, plus additional screws if required, see Figs. 8 and 9. Ensure that the mains cable is fed through the rectangular cut out and is not trapped between the outer cover box and the floor. It is recommended to use 4 additional screws at the ends of the mounting brackets.

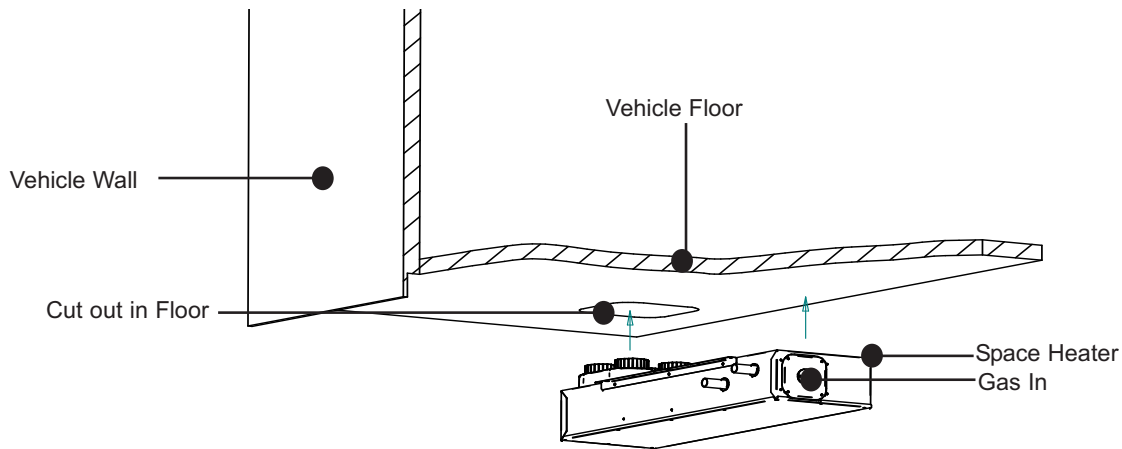

Fig. 8 - Positioning the Space Heater

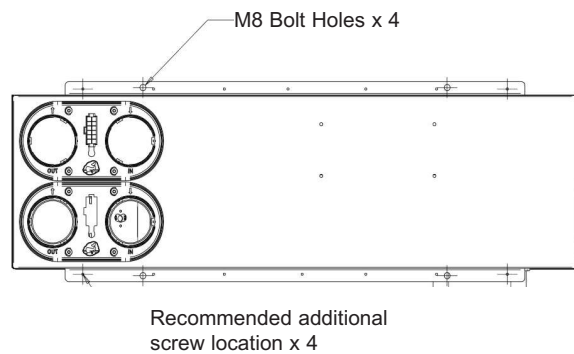

Fig. 9 - Securing the Space Heater (Plan View)

Step 3: Securing the Flues

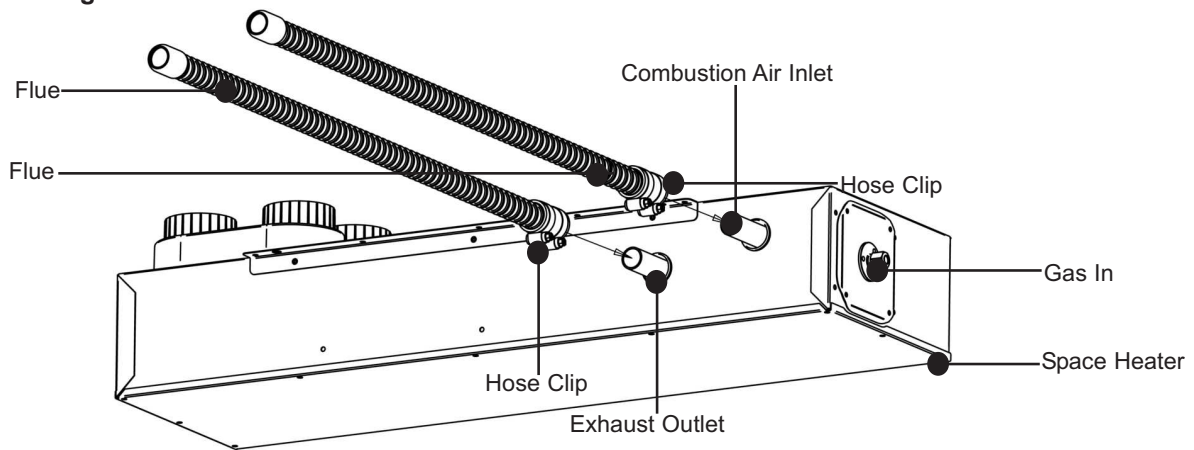

Fig. 10 - Attaching Flues

Push on the ends of the flues with the blue adaptor to the pipes on the underside of the Space Heater ensuring they are fully pushed on, then secure with supplied hose clips (see Fig. 10).

Step 4: Mounting the Flues

When mounting the combustion air inlet flue and exhaust flue, they **must** run downwards from the Space Heater to their open end to allow any condensation to drain out. The open ends **must be** angled downwards to prevent rain from entering. Care **must be** taken to route exhaust flues around chassis members, avoiding gas pipes and wires.

The flues **must** otherwise be kept as straight as possible.

The exhaust flue **must be** positioned to avoid contact with combustible materials, such as the caravan floor or skirt. Brackets can be used to ensure that the hot flue has a safe gap around it.

Please note: The exhaust flue **must be** positioned at the side or the rear end of the vehicle. The open end of the combustion air flue **must be** at least 500mm away from the open end of the exhaust flue and pointing in the same direction.

The combustion air inlet flue is attached to the underside of the floor with two brackets. The exhaust flue **must be** secured in the same way. Clip the bracket around the flue and use two screws (No.8 x 3/4") to attach each bracket to the floor as per Fig.11.

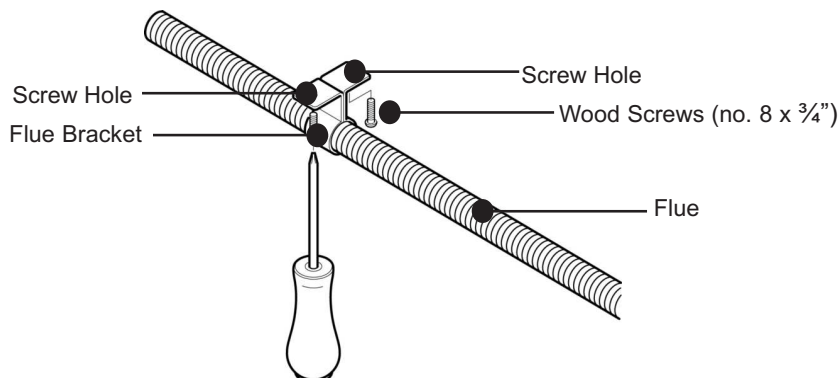

Fig. 11 - Secure Flue Brackets

Step 5: Connect to Gas Supply

The appliance **must be** installed by a competent person in accordance with the installation instructions and comply with any relevant regulations in the country where the appliance is installed.

The Space Heater is supplied with a compression nut and olive for 8mm (5/16") pipe. The supply pipe **must be** checked and be free from dirt or other particles before connection to the compression joint on the Space Heater. The supply pipe **must be** routed so that the appliance can be removed for servicing. A gas shut-off valve **must be** located in the vicinity of the Space Heater and all connections **must be** kept to a minimum.

A gas pressure test point **must be** fitted to the inlet of the appliance.

When the gas line is complete, all joints **must be** tested for leaks using air to measure the pressure drop, leak detection fluid can then be used. **Never with a naked flame.**

The gas pressure **must be** verified at the pressure test point.

Please note: The operating pressure for the gas supply in caravans and motorhomes **must be** 30mBar.

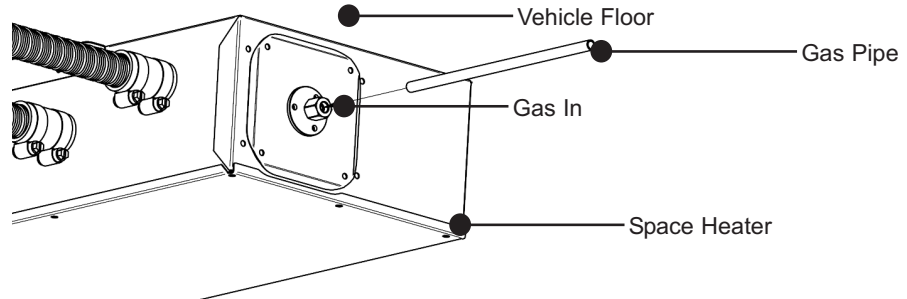

Fig. 12 - Connect to Gas Supply

Step 6: Fitting Hot Air Ducts

To fit the ducting, push it onto the 'outlet' ports, where it will be gripped by the nozzle (see Fig. 13). When fitting the air ducts, ensure that the outlet ducts are fitted to the hot air out (red) fitting and the inlet ducts are connected to the cold air in (black) fitting.

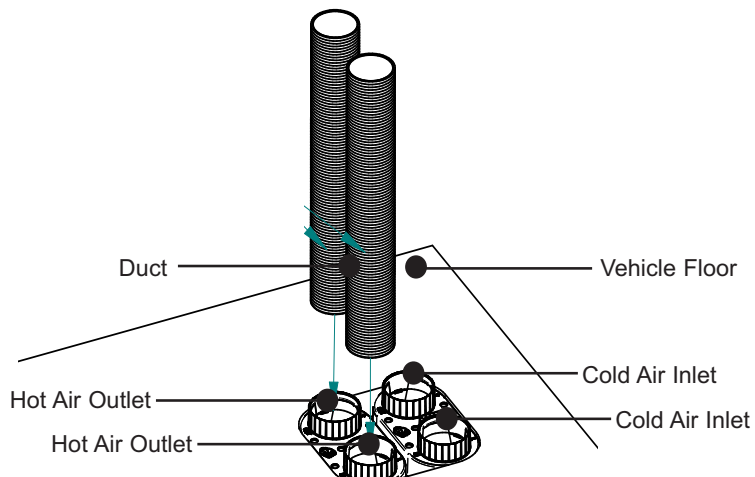

Fig. 13 - Fitting Hot Air Ducts

Important: At least one hot air outlet vent **must be** permanently open on each branch of ducting. The hot air duct **must not** be fed into the centre branch of a T fitting, as per Fig. 14.

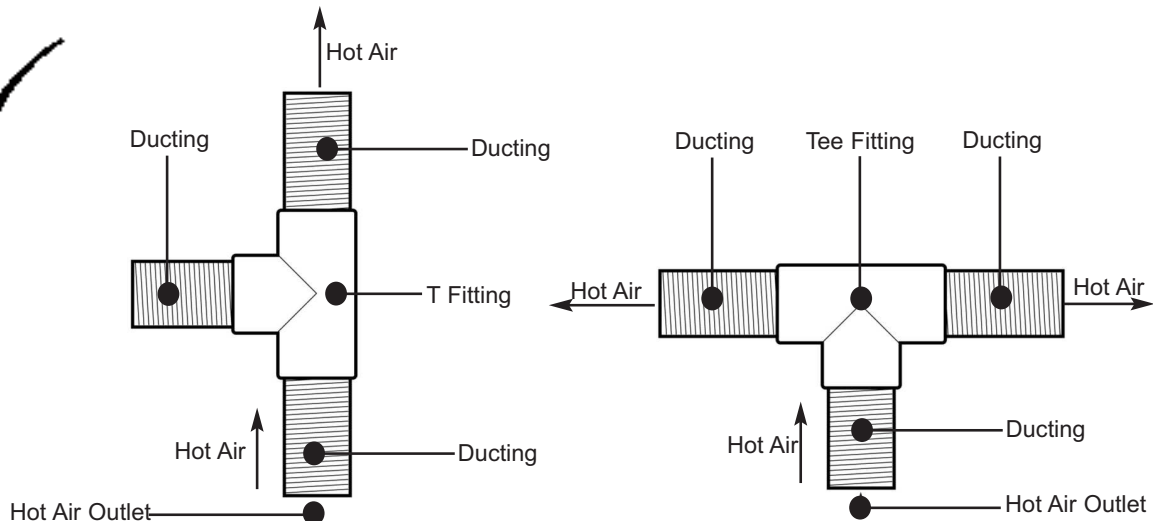

Fig. 14 - Tee Fitting Orientation

Step 7: Fitting Cold Air Supply

The Whale® Space Heater **must be** adequately supplied with cold air. If the Space Heater is installed in a bed box or another confined space, either vents into the area **must be** fitted or ducting used to supply the Space Heater with cold air. If a vent is fitted, it **must be** no smaller than one designed for use with 60mm ducting. If ducting is fitted it **must** supply air from the living space of the vehicle. To fit the ducting, push it onto the cold air inlet ports, where it will be gripped by the nozzle (see Fig. 15).

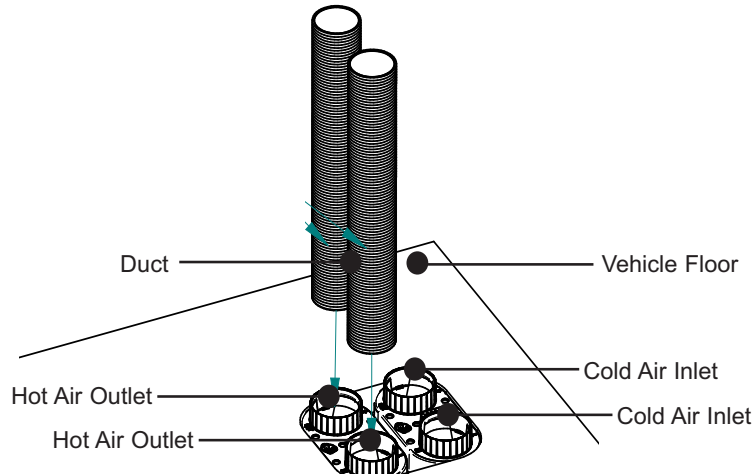

Fig. 15 - Fitting Cold Air Ducts

Step 8: Installing Whale® Control Panel

- Option 1 - Installing Whale Space Heater Control Panel
- Option 2 - Installing Whale iVan Wireless Control Panel
- Option 3 - Installing Whale Duo Control Panel
- Option 4 - Installing Vehicle Manufacturer Control Panel

Option 1 - Installing Whale Space Heater Control Panel

The Whale Space Heater Control Panel requires a cut out 95mm wide x 42mm high. Feed the wires through the cut out in the wall and locate into desired position. Secure with 4 screws (No.4 x $\frac{3}{4}$) provided, then clip on the surround frame.

In some instances, it may be necessary to make the wiring connections in Step 9 before securing the Control Panel to the wall. **Please note:** It may be possible to retrofit the Whale® Control Panel into existing frames.

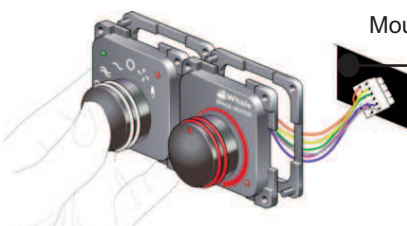

Fig. 16 Insert Control Panel

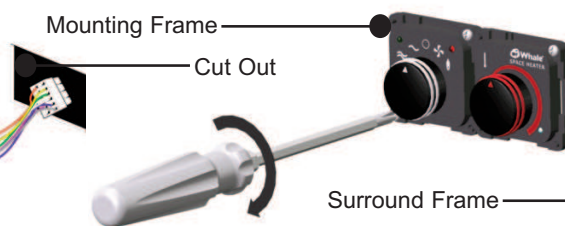

Fig. 17 Secure Control Panel



Fig. 18 Installed Control Panel

Option 2 - Installing Whale iVan® Wireless Control Panel

When installing the Whale iVan® Control Panel, find a suitable convenient and accessible position.

For good temperature control, select a central position away from draughts, direct sunlight and approximately 1.5 metres above the floor. Ensure suitable access for connecting to the 12V d.c. supply. The minimum panel cut out depth for the controller and wiring **must be** 15mm.

- i. Position the supplied cutting template in the chosen location and temporarily secure with low tack adhesive. Using a suitable 10mm drill bit, drill through the template and the panelling behind, in the four corners marked on the template. Then cut out the rectangular shape by cutting along the dotted lines. Finally, drill the 4 screw holes with a 2mm drill bit. Discard the remains of the cutting template.
- ii. Feed the wires through the newly cut hole, and position the controller so that the screw holes line up with those that have been drilled. Secure in place with the 4 small screws supplied (No.6 × 5/8" pan head screws).
- iii. Connect the positive and negative wires from the back of the controller into the vehicle's electrical system. iVan should be protected through a 1 Amp automotive fuse.
Please Note: The manufacturer cannot be held responsible for claims arising from incorrect installation, unauthorised modification or misuse of this product.
- iv. Reconnect / turn on the power supply. The control panel should turn on. You will be asked to set the time.

To Set the Time:

- Press and hold the Home Button to enter the 'Setup and Options' screen
- Touch 'Set Clock'
- Adjust the time with the + and - keys, and select to adjust hours or minutes with the left and right arrows.
- Press the 'Home' button to return to the 'Home' screen.

Connecting iVan® to the Heaters:

Turn on the Water Heater, Space Heater and Control Panel at the **same time** by using the master switch in the vehicle. When the Water Heater, Space Heater and Control Panel are switched on (it is important that they turn on at the same time), within a few seconds "A Water Heater has been found" and "A Space Heater has been found" message will appear on the screen. Press OK both times and the Water and Space Heater will be paired to the Control Panel.

Option 3 - Installing Whale Duo Control Panel

The Whale Duo Control Panel requires a cut out 118mm wide x 64mm high. Feed the wires through the cut out in the wall and locate into desired position. Secure with 2 screws (No.4 x 3/4) provided, then clip on the surround frame.

In some instances, it may be necessary to make the wiring connections in Step 9 before securing the Whale Duo Control Panel to the wall.

Option 4 - Installing Vehicle Manufacturer Control Panel

If your vehicle is fitted with an alternative control panel, please refer to the instructions provided by the control panel manufacturer or your vehicle handbook.

Step 9: Electrical Connections 12V

Vehicle Manufacturer Installation



WARNING: Always disconnect the appliance from the power supply prior to working on electrical components. The Space Heater and Control Panels come complete with electrical connectors fitted.

All Whale Control Panels are designed to be integrated into the caravan's wiring loom. The Space Heater is provided with a JST VL series 12 way socket and the Control Panel with JST VL 6 and 3 way sockets. 9 wires are required to connect the Space Heater to the Control Panel, the 12V d.c. power supply (red wire) and the 0V d.c. power supply (white wire). The wires **must be** connected to the 12 way socket at the Space Heater as shown in Tables 1a and 2.

Please note: The Space Heater **must be** installed in-line with a 5 Amp automotive fuse. Whale recommends that a 5 Amp automotive fuse is fitted in the 12 V d.c. supply.

Table 1a: Connections at Space Heater

Terminal Number	Description	Wire Colour
1	Switch common	Brown
2	0V to Switch panel	Black
3	Fan Switch	Yellow
4	Electric 1 Switch	Green
5	Electric 2 Switch	Grey
6	Electric 3 Switch	Pink
7	Burner Switch	Blue
8	Burner LED	Orange
9	Lockout LED	Violet
10	12V supply	Red
11	0V supply	White

Table 1b: Connectors at SC Only

Male RJ12 Connector	Communication Cable	Colour may vary
---------------------	---------------------	-----------------

Table 2: Connections at Control Panel

Connector	Terminal Number	Description	Wire Colour
6 Way connector	1	Switch common	Brown
	2	Burner Switch	Blue
	3	Fan Switch	Yellow
	4	0V to Switch panel	Black
	5	Burner LED	Orange
	6	Lockout LED	Violet
3 Way connector	1	Electric 1 Switch	Green
	2	Electric 2 Switch	Grey
	3	Electric 3 Switch	Pink

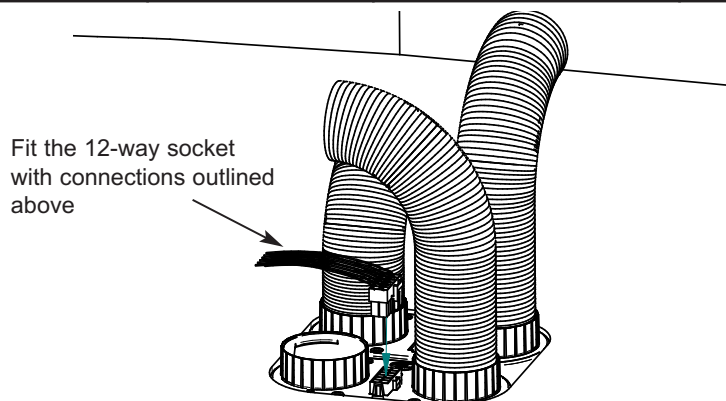

Fig. 19 - Connect 12V d.c. to Interface Plate

Step 10: Electrical Connection 230V

The appliance **must be** installed in accordance with the installation instructions and comply with any relevant regulations in the country where the appliance is installed. Electrical installation **must be** carried out by a suitably qualified electrician. The electrical supply **must be** connected to a 13 Amp fused spur provided with an all-pole disconnection and the appliance **must be** earthed.

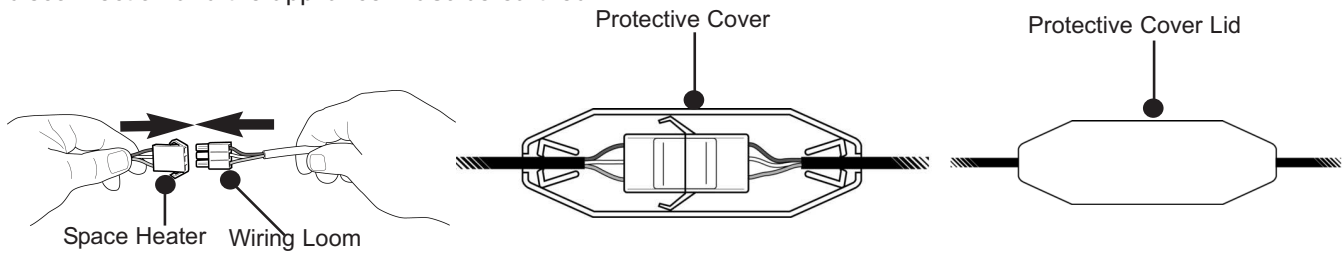

Fig. 20 Mains Electrical Connection

Vehicle Manufacturer Installation Example

The mains supply cable is supplied with a JST LP series socket as shown in Fig 20 (terminal pins are JST slm-61T-2.0) and **must be** mounted in a housing with strain relief to prevent accidental disconnection and prevent access to the connector.

Please note: If the supply cable is damaged, it **must be** replaced by the caravan/motorhome/cable manufacturer or a Whale® Approved Service Centre or Technician.

Warning: The appliance **must not** be supplied through an external switching device, such as a timer, or a circuit that is regularly switched. This is to avoid an inadvertent resetting of the thermal cut out.

N.B. Ensure that the Space Heater is not located immediately below the electrical supply socket.

Completed installation:

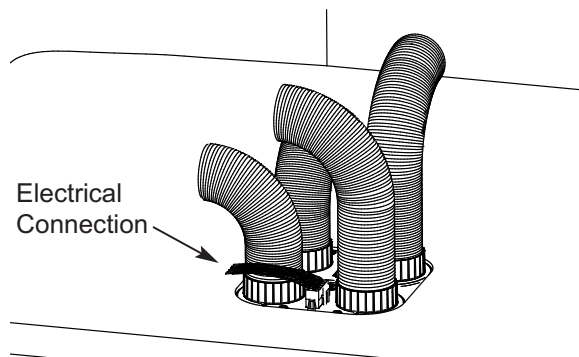

Fig. 21 - Completed Installation

Please note: After completing the installation, a full function check including gas soundness **must be** carried out to ensure the appliance has been installed and operates correctly. The gas soundness check **must be** carried out by an accredited LPG engineer and a test certificate issued.

7. INSTRUCTIONS FOR USE

To the User:

Read the following instructions carefully.



Observe all warnings.

In the unlikely event of leaks in the gas system, or if there is a smell of gas:

- Extinguish all naked flames
- Do not operate any electrical switches
- Turn off all gas appliances
- Open windows and doors for ventilation
- Do not smoke
- Shut off gas connection

Ensure that the system is immediately and thoroughly checked by a Whale® Approved Service Centre or Whale Service Engineer.

The Space Heater **must not** be operated in the following situations:

- When refuelling the vehicle, refuelling the vehicle towing the caravan or refuelling any other appliances.
- When the vehicle in which the Space Heater is installed is in a confined space (such as a garage).
- When the vehicle in which the Space Heater is installed is in motion, unless a vehicle in motion kit is installed. Please see Appendix for information on identifying flue type.

This appliance is not intended for use by persons (including children) with reduced physical, sensory or mental capabilities, or lack of experience and knowledge, unless they have been given supervision or instruction concerning use of the appliance by a person responsible for their safety. Children must be supervised to ensure that they do not play with the appliance.

Ensure that a minimum of one of the hot air outlet vents is permanently open.

When using gas, the combustion air flue and outlet openings for the products of combustion (exhaust flue) **must never be obstructed**. They **must be** checked regularly, and if necessary cleaned by the user (e.g. in winter, snow **must be** removed from the combustion outlet and air intake).

Where the open end of the exhaust flue terminates, three sides of the underfloor space **must be** kept open and not obstructed, and **must not** contain through-floor ventilation openings.

The Space Heater, its gas supply and flues for the products of combustion are to be inspected in accordance with national regulations or if these do not exist, the manufacturer's recommendations. Whale advises that this **must be** done at least annually.

The Whale® Space Heater **must be** checked periodically by a Whale® Approved Service Centre / Technician, or competent person, at least annually. This **must be** completed according to the practice in the country where it is used and according to the Whale® instructions. Whale recommends annual testing of gas soundness and combustion by an accredited LPG engineer. The appliance contains ESD sensitive components and therefore **must only** be opened by a Whale® Approved Service Centre / Technician (contact Whale® Support).

When using operating switches provided by the installer or vehicle manufacturer, they are responsible for providing user instructions and identification of symbols on the control panel.

The inlet vents of the Space Heater **must never** be blocked and at least one hot air outlet vent **must be** permanently open.

OPERATING INSTRUCTIONS

For operation of the Space Heater, a 12V d.c. supply must be connected at all times. To operate the Space Heater's electric elements, it must also be connected to a suitable 230V a.c. supply.

Option 1 - Whale Space Heater Control Panel

Option 2 - Whale Duo Control Panel

Option 3 - Whale iVan Wireless Control Panel

Option 4 - Vehicle Manufacturer Control Panel

Option 1 - Whale Manual Control Panel



Fig. 22 - Whale Space Heater Control Panel

For Fan Only Operation: Turn the selector knob to the 'fan' position.

For Gas Operation: Turn the selector knob to the 'gas on' (flame) position. There will be a pre-purge pause of approx. 30 seconds to allow any un-burnt gas to leave the flue. A green LED will light upon successful flame ignition. If there is air in the gas supply line it may take a few attempts for the gas to ignite. See Section 9 for gas lockout re-setting. If the ignition is not satisfactory the red LED on the Control Panel will flash, refer to the Trouble Shooting Guide (see Section 9).

For Electric Operation: The Space Heater is equipped with 3 power settings 500W / 1000W / 2000W.

Turn the selector knob to low power setting for 500W.



Turn the selector knob to medium power setting for 1000W.



Turn the selector knob to high power setting for 2000W.



When operating on low and medium electric power settings, the blown air fan runs at a reduced speed to minimise noise and current draw.

Note: The electric elements will still operate if the appliance is in gas ignition lock-out.

For Electric and Gas Boost Operation: The Space Heater will run on Gas and 1000W.

Turn the selector knob to Boost Operation.



Switching Appliance Off: Turn the selector knob to the 'Off' position (●).







Note: The fan will continue to run for 3 minutes to allow the Space Heater to cool down.

Adjusting The Temperature: Turn the temperature control knob clockwise to increase and anti-clockwise to reduce the room temperature. The Space Heater will automatically turn itself on and off to maintain the desired ambient temperature.

Note that the desired temperature must be above the actual room temperature for the heating to turn on and a power setting selected.

Note: The Control Panel incorporates a low temperature / frost protection setting. This can be activated by turning the temperature control knob fully anti-clockwise with a gas or electric setting turned on.

Table 3: Whale Control Panel Functions

Symbol	Setting	Description
	OFF	The Space Heater will be off. Once the Space Heater is switched off, it will purge for 3 minutes to allow the components to cool down.
	Fan	The Space Heater will operate on fan only.
	Gas	The Space Heater will operate on gas only. There will be a pre-purge time of around 30 seconds before ignition. When the gas is lit, the green LED will be illuminated. If the Space Heater fails to light for any reason, the red LED will flash. Refer to the Trouble Shooting Guide (Section 9).
	Electric Low	The Space Heater will operate at 500W on electric setting.
	Electric Medium	The Space Heater will operate at 1kW on electric setting.
	Electric High	The Space Heater will operate at 2kW on electric setting.
	Boost / Dual	The Space Heater will operate on gas and electric simultaneously. Depending on the temperature inside the Space Heater, it may automatically run on 1kW, 0.5kW or 0kW electric. When the gas is in operation, the green LED will be lit. If there are any problems with operation, the red LED will flash. Refer to the Trouble Shooting Guide (see Section 9).

Option 2 - Operating Whale Duo Control Panel

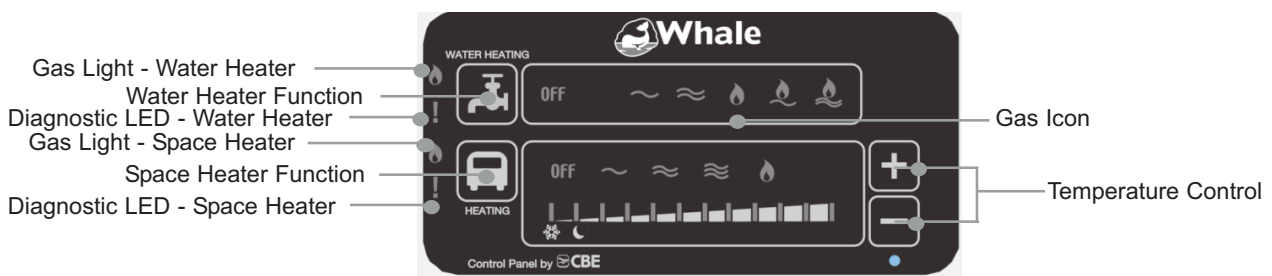



Fig. 23 - Whale Duo Control Panel

For Gas Operation - Space Heater: Press the Space Heater Function key until the 'gas' icon is illuminated. There will be a pre-purge pause of approx. 30 seconds to allow any un-burnt gas to leave the flue. A green LED will light upon successful flame ignition. If there is air in the gas supply line it may take a few attempts for the gas to ignite. See Section 9 for gas lockout re-setting. If the ignition is not satisfactory the Space Heater Red Diagnostic LED '!' on the Control Panel will light. If the Diagnostic LED is lit please refer to the Trouble Shooting Guide (see Section 9).

For Electric Operation - Space Heater: The Space Heater is equipped with 3 power settings 500W/1000W/2000W.

For 500W, Press the Space Heater Function key until the 'low power setting' icon is illuminated. 

For 1000W, Press the Space Heater Function key until the 'medium power setting' icon is illuminated. 

For 2000W, Press the Space Heater Function key until the 'high power setting' icon is illuminated. 

When operating on low and medium electric power settings, the blown air fan runs at a reduced speed to minimise noise and current draw.

Switching Appliance Off: Press the Space Heater Function key until 'Off' is illuminated.

Note: The fan will continue to run for 3 minutes to allow the Space Heater to cool down.





For Electric and Gas Boost Operation: The Space Heater will run on Gas and 1000W Electric.

Press the Space Heater Function Key until  is illuminated.

Adjusting The Temperature: Use the temperature control buttons to adjust the temperature. Press ' + ' to increase the temperature. Press ' - ' to decrease the temperature. The Space Heater will automatically turn itself on and off to maintain the desired ambient temperature. Note that the desired temperature must be above room temperature for the heating to turn on.

Note: The Control Panel incorporates a low temperature / frost protection setting. This can be activated by pressing ' - ' until the frost icon is illuminated.

Table 4: Whale Duo Control Panel Functions

Symbol	Setting	Description
OFF	OFF	Space Heater will be off.
	Gas	Space Heater will operate on gas. There will be a pre-purge time of around 30 seconds before ignition. When the gas is lit, the green LED will be illuminated. If the Space Heater fails to light for any reason, heater will lockout. Refer to Trouble Shooting Guide (Section 9).
	Electric Low	Space Heater will operate at LOW on electric setting.
	Electric Medium	Space Heater will operate at MEDIUM on electric setting.
	Electric High	Space Heater will operate at HIGH on electric setting.
	Boost / Dual	The Space Heater will operate on gas and electric simultaneously. Depending on the temperature inside the Space Heater, it may automatically run on 1000W, 500W or 0W electric. When the gas is operating, the green LED will be lit. If there are any problems with operation, heater will lockout, refer to the Trouble Shooting Guide (see section 9).

Option 3 - Operating Whale iVan[®] Wireless Control Panel

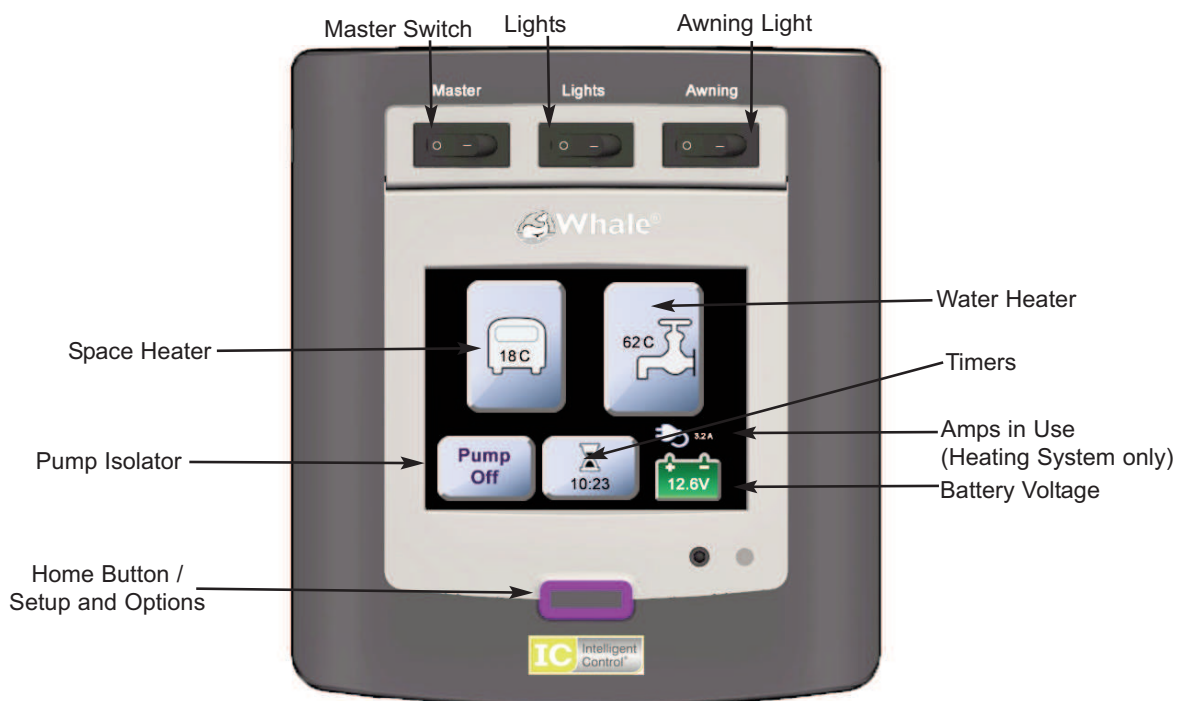

Fig. 24 - Whale iVan[®] Control Panel

Operating the Space Heater

1. From the home screen, touch the 'van' icon:-
2. The following screen will appear:-



3. Select the desired heat setting by tapping one of the icons; the icon will turn green to show it has been activated.

Note: The Space Heater will not operate if the desired temperature is below the current room temperature.

Option 4 - Vehicle Manufacturer Control Panel

If your vehicle is fitted with an alternative control panel, please refer to your vehicle handbook.

8. MAINTENANCE

If the Space Heater has not been used for some time, dust may have settled inside the Space Heater and the ducting. Run the Space Heater on the "Fan only" setting (if available) until it clears. The outside of the appliance should not normally require cleaning. If it does, isolate the electrical supplies and wipe down with a soft, damp cloth only. Do not use abrasive cleaners. Allow to fully dry before reconnecting the electrical supplies.

The Whale® Space Heater must be checked periodically by a Whale® Approved Service Centre / Technician, or competent person, at least annually. This must be completed according to the practice in the country where it is used and according to the Whale® instructions. Whale recommends annual testing of gas soundness and combustion by an accredited LPG gas engineer. The appliance contains ESD sensitive components and therefore **must only** be opened by a Whale® Approved Service Centre / Technician (contact Whale® Support).

9. TROUBLESHOOTING

The Space Heater is equipped with an electronic diagnostic system which will detect fault conditions ranging from poor gas or d.c. supply to internal Space Heater malfunctions.

Option 1 - Whale Space Heater Control Panel

In the unlikely event of a failure, the red LED on the Control Panel will flash a number of times, pause, and repeat until switched off. Count the number of flashes and refer to the table below. Ensure fan has stopped before cycling power to prevent an overheat lockout.

Option 2 - Whale Duo Control Panel

In the unlikely event of a failure, the red '!' LED on the Control Panel will light. To identify the lockout press and hold the Space Heater Function Button. The temperature control bars will light to indicate the fault code e.g if 1 bar lights, the fault code is 1, if 2 bars lights, the fault code is 2 etc. Identify the fault code and refer to the table below.

Option 3 - Whale iVan® Control Panel

In the unlikely event of a failure, a pop-up screen will appear with either a tap icon to indicate there is a problem with the Water Heater, or a van icon to indicate there is a problem with the Space Heater. Follow the instructions on screen as outlined in the table on pages 21 - 22.

Option 4 - Vehicle Manufacturer Control Panel

If your vehicle is fitted with an alternative control panel, please refer to the instructions provided by the control panel manufacturer or your vehicle handbook.

Table 5: Space Heater Fault Finding

Number of flashes / Bars lit	Fault	Remedy
1	No Flame Detected	Check gas supply making sure there is gas in the bottle and no blockage in the gas line. Ensure that if the temperature is below 5°C, only propane gas is used. Clear lockout as described below.
2	Overheat	Check the air ducts and vents are not blocked or restricted. Whale recommends that you wait at least 5 to 10 minutes to allow the Space Heater to cool before clearing lockout as described below.
3	Low/High Supply Voltage	Note if high electric setting is used the minimum operating voltage is 11.5V and maximum is 15V, when measured at the Space Heater. Check battery voltage. If between 11.5V and 15V, check connections between Space Heater and battery. Check alternator or external battery charging. Clear lockout as described below.
4	Combustion Air Fault	Check combustion air inlet flue and exhaust flue for blockages. Clear lockout as described below.
5	Other / Internal Fault	Attempt to clear lockout as described below. If this fails, contact Whale Support on +44 (0)845 217 2933 .
Solid / All bars lit	General Fault	Two faults have occurred at the same time OR five or more lockout clearing attempts have been unsuccessful. Clear lockout by pressing the red Reset Button on the Space Heater as described on page 21.

Lockout Clearing Procedure

Option 1 - Whale Space Heater Control Panel & Option 2 - Whale Duo Control Panel

If the Space Heater lockout condition has been identified by **1, 3, 4 or 5 flashes/bars**, the lockout **must be** cleared by turning the d.c. power 'off' and then 'on' again at the master switch in the vehicle. If the first attempt is unsuccessful, you can retry an additional 4 times. If the lockout still will not clear (identified by a solid LED or has all bars lit), please press the red Reset Button on the Space Heater held in for 1 second (see Fig. 25).

If the Space Heater lockout condition has been identified by **2 flashes/bars**, the lockout **must be** cleared by pressing the red Reset Button on the Space Heater once (see Fig. 25).

If the Space Heater lockout condition has been identified by a **solid red LED or all bars lit**, the lockout **must be** cleared by pressing the red Reset Button on the Space Heater once (see Fig. 25).

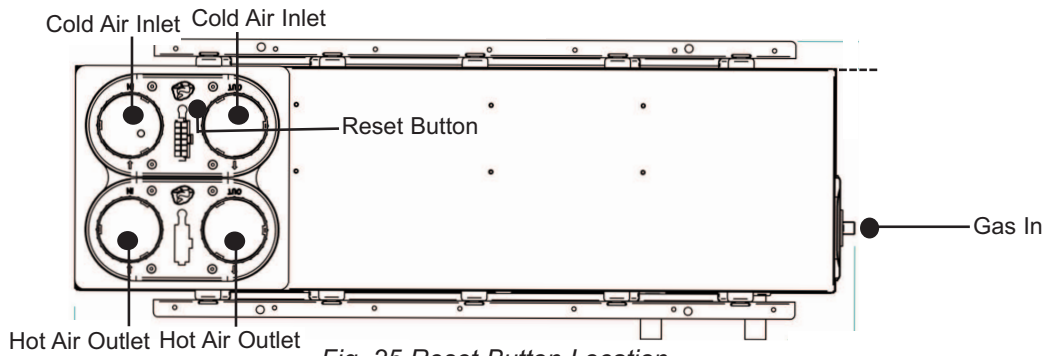
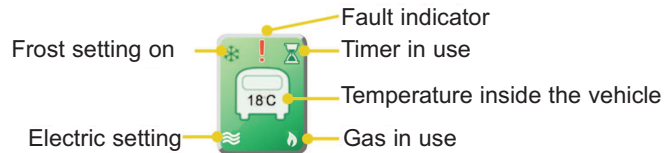

Fig. 25 Reset Button Location

If the problem persists contact **Whale Support on +44 (0)845 217 2933**.

Option 3 - Whale iVan® Control Panel

iVan® is equipped with an electronic diagnostic system which will detect fault conditions ranging from poor gas or d.c. supply to internal Water or Space Heater malfunctions. In the unlikely event of a fault, this will be indicated by a red '!' on the Water or Space Heater icon on the Home Screen.



The Space Heater will not operate when a fault is indicated on the home screen. A pop-up screen will appear when you attempt to operate the Space Heater. The pop-up screen identifies the fault. As soon as you have completed the suggested actions on the fault screens below, you **must** clear the fault code by following the instructions on screen. The instruction will be either to turn the Master Switch 'Off' then 'On' OR to press the Reset Button once. (The red Reset Button can be found on the top of the Space Heater, beside the cold air inlet, see Fig. 25).

When the lockout has been cleared successfully, the Space Heater will default to 'Off'. The user must select the desired power operation to operate the Space Heater. Please follow the advice on screen, as outlined below.

Table 6: Space Heater Fault Screens

Fault	Fault Screen	Solution
"Check gas supply" (1)		Ensure that there is gas in the gas bottle and that there is no blockage in the gas line. Ensure that if the temperature is below 5°C, only propane gas is used. Once the checks are complete, press the Reset Button on the Space Heater once, then press OK on the iVan® Control Panel. This will clear the fault code. If there is a problem with the gas supply which cannot be dealt with immediately, select an electric heating option. If the fault does not clear, please contact Whale Support on +44(0)845 217 2933 .
"Gas overheating fault" (2) OR "Electric overheating fault" (3)		Check the air ducts and vents are not blocked or restricted. Whale recommends that you wait at least 5 to 10 minutes to allow the Space Heater to cool before clearing the lockout by pressing the Reset Button on the Space Heater once, then press OK on the iVan® Control Panel. This will clear the fault code. If the fault does not clear, please contact Whale Support on +44(0)845 217 2933 .

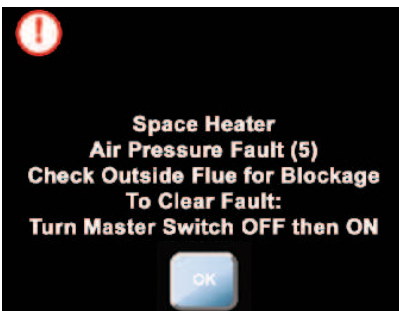
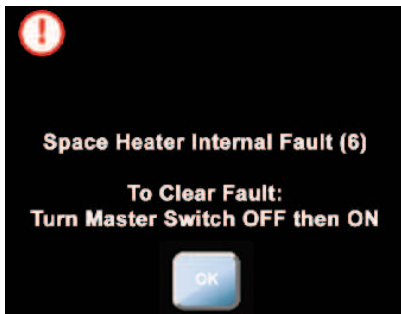
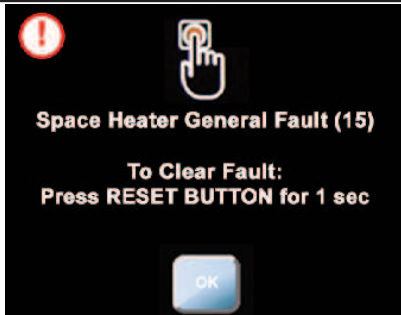
Fault	Fault Screen	Solution
“Voltage Supply fault” (4)		<p>Note if high electric setting is used the minimum operating voltage is 11.5V and maximum is 15V, when measured at the Space Heater. Check battery voltage. If between 11.5V and 15V, check connections between Space Heater and battery. Check alternator or external battery charging. Clear lockout by turning the Master Switch ‘off’ then ‘on’. This will clear the fault code. If the fault does not clear, please contact Whale Support on +44(0)845 217 2933.</p>
“Air Pressure fault” (5)		<p>Check combustion air inlet flue and exhaust flue for blockages. Clear lockout by turning the Master Switch ‘off’ then ‘on’. This will clear the fault code. If the fault does not clear, please contact Whale Support on +44(0)845 217 2933.</p>
“Thermistor fault” (6) OR “Flame simulation fault” (7) OR “Relay sense fault” (8) OR “Start-up fault” (9) OR “Configuration fault” (10) OR		<p>An internal fault has occurred, to clear the lockout press the Reset Button on top of the Space Heater once, then press OK on the iVan® Control Panel. This will clear the fault code. If the fault does not clear, please contact Whale Support on +44(0)845 217 2933.</p>
“General fault” (15)		<p>Two faults have occurred at the same time OR at least five or more lockout clearing attempts have been unsuccessful. Clear lockout by pressing the red Reset Button on the Space Heater as described on page 21. If the fault does not clear, please contact Whale Support on +44(0)845 217 2933.</p>

10. WINTERISING

When using the Space Heater in winter, ensure the flues are not blocked by snow or fallen leaves etc. If the Space Heater is not going to be used for a long period of time, Whale recommends that the open end of the combustion air and exhaust flue are covered to prevent ingress of leaves etc.

11. SERVICE SUPPORT DETAILS

For installation or serviceable parts advice please contact Whale® Customer Support:

Tel: +44 (0)845 217 2933

Email: info@whalepumps.com

12. EU DECLARATION OF CONFORMITY

Description of Equipment: **Gas and Electric Space Heater**

Manufacturer's Declaration

We hereby declare, under our sole responsibility, that the above equipment complies with the provisions of the following EC Directives.

Gas Appliance Regulation (EU) 2016/426 (GAR) on the approximation of the laws of the Member States relating to appliances burning gaseous fuels.

Low Voltage Directive 2014/35/EU on the harmonization of the laws of the Member States relating to electrical equipment designed for use within certain voltage limits.

Electromagnetic Compatibility Directive 2014/30/EU, on the approximation of the laws of the Member States relating to automotive electromagnetic compatibility.

ECE Regulation No.122, Uniform technical prescriptions concerning the approval of vehicles of categories M; N and O with regard to their heating systems.

CE mark first affixed: July 2012

Basis on which conformity is declared; The above equipment complies with the protection requirements of the EMC Directive and the principal elements of the safety objectives of the Low Voltage Directive

Please contact Whale® if further details are required.

Richard Bovill
Engineering Director

13. PATENTS AND TRADEMARKS

The Whale® Space Heater is patent pending protected by the following patent and design registration applications:

UK Patent application number No.s 12022425.3, 0902533.9 and 0915825.4.

Whale® and iVan® are a registered trademark of Munster Simms Engineering Ltd (also trading as Whale®).

14. WARRANTY

The Whale® Space Heater is covered by a standard 3 year warranty, unless otherwise stated in your van's manual. Please complete the enclosed warranty card and return to Whale.

For warranty details, please see the enclosed warranty statement.

© Copyright Whale® 2018 - All rights reserved. Reproduction in whole or in part without permission is prohibited. WHALE®, is a registered trademark of Munster Simms Engineering Limited, Bangor, Northern Ireland trading as Whale. Whale's policy is one of continuous improvement and we reserve the right to change specifications without prior notice. Illustrations are for guidance purposes only.

Neither the accuracy nor completeness of the information contained in this or any product literature is guaranteed by the Company and may be subject to change at its sole discretion.

15. APPENDIX - IDENTIFYING THE FLUE AND INSTALLATION TYPE

See below for identification of the flue type and installation.

C₅₃ Flue Type – Standard installation

If the installation and flues are type C₅₃, the flues remain separate and exit the vehicle wall at least 500mm apart. Please note: Some installations may use a single bracket to secure each flue individually, but they will still be located at least 500mm apart.



Fig. 26 Flue Type for Standard Installation C₅₃

C₁₃ Flue Type – for Vehicle in Motion

The C₁₃ type utilises the Vehicle in Motion Double Flue Bracket, whereby both flues exit the vehicle wall via the same bracket, with one flue located above the other (see below). For reference, the Exhaust Flue **must always** be located above the Inlet Flue.

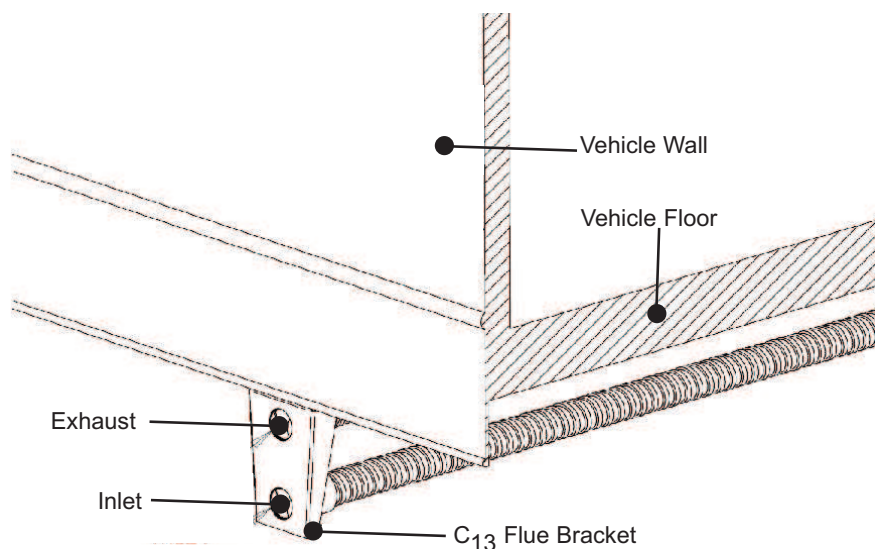

Fig. 27 Flue Type for Vehicle in Motion C₁₃